

Supply facility and input/output point locations in the presence of barriers

By: Shoou-Jiun Wang, Joyendu Bhadury and Rakesh Nagi

J. Bhadury, S.J. Wang and R. Nagi "Supply Facility and Input/Output Point Locations In The Presence of Barriers". *Computers and Operations Research*, Vol. 29, 685-699 (2002).

Made available courtesy of Elsevier: <http://www.elsevier.com/>

*****Reprinted with permission. No further reproduction is authorized without written permission from Elsevier. This version of the document is not the version of record. Figures and/or pictures may be missing from this format of the document.*****

Abstract:

This paper studies a facility location model in which two-dimensional Euclidean space represents the layout of a shop floor. The demand is generated by fixed rectangular-shaped user sites and served by a single supply facility. It is assumed that (i) communication between the supply point and a demand facility occurs at an input/output (I/O) point on the demand facility itself, (ii) the facilities themselves pose barriers to travel and (iii) distance measurement is as per the L_1 -metric. The objective is to determine optimal locations of the supply facility as well as I/O points on the demand facilities, in order to minimize total transportation costs. Several, increasingly more complex, versions of the model are formulated and polynomial time algorithms are developed to find the optimal locations in each case.

Scope and purpose

In a facility layout setting, often a new central supply facility such as a parts supply center or tool crib needs to be located to serve the existing demand facilities (e.g., workstations or maintenance areas). The demand facilities are physical entities that occupy space, that cannot be traveled through, and that receive material from the central facility, through a perimeter I/O (input/output or drop-off/pick-up) point. This paper addresses the joint problem of locating the central facility and determining the I/O point on each demand facility to minimize the total material transportation cost. Different versions of this problem are considered. The solution methods draw from and extend results of location theory for a class of restricted location problems. For practitioners, simple results and polynomial time algorithms are developed for solving these facility (re) design problems.

Keywords: Optimal I/O point location, Minisum location, Location with barriers, Shortest path, Facility layout, Rectilinear metric

Article:

1. Introduction

Facility layout problems frequently require the application of tools and techniques from Location Theory. Examples of such applications include Co et al. [1], Dowling [2], Houshyar and McGinnis [3], Kim [4], and Welgama and Gibson [5]. An excellent coverage of these two areas and their overlap is available in the well-known text of Francis et al. [6]. A common scenario in many of these problems is to locate a service facility, say a parts supply center, to serve a set of demand centers, which may be manufacturing cells or workstations; it is required to locate this facility in order to minimize the total material handling cost. Whereas there are well-known location models, such as the *Minisum* model (Francis et al. [6]) for such problems, they almost always assume that the supply and demand centers are infinitesimally small and hence, pose no barrier to travel or location. While such an assumption may be reasonable when the facility to be located is infinitesimally small compared to the area where it can be located (e.g. when choosing the location of a store in a city), it may not be valid for layout problems. These problems frequently originate on the shop floor where equipment, machinery, workstations, etc. may be demand centers themselves, but also occupy substantial space and pose barriers to travel and location. Motivated by such limitations, there has been some research done on the location of facilities in the presence of *forbidden regions*, i.e., regions that pose a barrier to location and transportation —

see for example Katz and Cooper [7, 8 and 9], Batta et al. [10], Larson and Sadiq [20] and, more recently, Butt and Cavalier [11], Hamacher and Nickel [12], Brimberg and Wesolowsky [13] and Savas et al. [14]. The fact that transportation in these models is accomplished in the presence of impenetrable barriers requires computation of shortest paths in the presence of obstacles; a problem first studied by Lozano-Perez and Wesley [15] and later, by Larson and Li [16], Alt and Welzl [19].

Despite the progress made in considering more realistic travel metrics in the presence of finite-sized impenetrable barriers, it is noted that the median to be located usually remains infinitesimal in size. An notable exception is the work of Savas et al. [14]. In their work, however, the demand facilities have fixed and predetermined perimeter points through which material handling takes place. Methodologically, this implies that the computation of shortest paths in the presence of obstacles has specific termination points. However, in many, if not most, manufacturing layout situations, such an assumption is excessively restrictive. In most cases, the material handling points can be freely chosen on the perimeter of the demand facilities, and restricting them can result in excess material handling costs.

This paper attempts to address the above concern by considering a shop floor layout, which has fixed rectangular-shaped demand facilities inside it. It is desired to locate a central facility, such as a parts supply center, which supplies desired materials to each demand facility (e.g. a workstation or a maintenance area). We begin with the assumption that this central facility is an infinitesimal point (referred to as a *supply point*) and then relax this assumption later, allowing for it to be described by a fixed rectangular shape too. We further assume that each demand center is a physical entity that occupies space and communicates, i.e., receives material from the central facility, through an I/O (input/output or drop-off/pick-up) point located on its periphery.

The objective then is to simultaneously find the location of the central facility and one I/O point on each demand facility to minimize the total material transportation cost (or weighted distance). The complication lies in that the finite areas of demand centers and supply facility act as barriers to travel. Thus every travel path must be a *feasible* path, in the sense that the path should not properly intersect with (penetrate) any finite-area entity/facility. We begin by considering the case of a supply point and assume its location is fixed. Having solved this initial case, we relax this constraint of fixed location by stipulating that the supply point can be located anywhere within a given rectangular region that does not physically overlap with the demand facilities. These results are then extended to the case where the supply point can be anywhere in the layout, without overlapping the demand facilities. Our final variant is one where the supply facility is a finite dimensional rectangle and it is required to determine the optimal locations of (i) the supply facility, (ii) the I/O point on the supply facility, and (iii) the individual I/O points of the demand facilities. Polynomial time algorithms are developed for each case.

The remaining paper is organized as follows. Section 2 discusses preliminaries, introduces notation and formulates the basic location problem under study. In Section 3, a solution to determine the optimal I/O points on demand facilities is presented, considering a fixed infinitesimal supply facility. In Section 4, we relax the assumption of fixed location but still constrain the infinitesimal supply facility to be located within a rectangular area. This is followed by Section 5, where we discuss the version where the supply facility itself is rectangular-shaped. Section 6 presents some efficiency improvement rules. Finally, Section 7 summarizes the paper and presents avenues for future research.

2. Problem formulation

Facility layout problems have been viewed in the literature in one of the following two ways (see Meller and Gau [17]): either as departmental (also called block layout), which tends to be space-filling or as detailed (also called machine or cellular) layout that tends to further specify exact resource locations, such as aisle structures, I/O points, etc. The facility layout context which provides the framework of our location problem is of the second type; hence it is not space-filling. We begin by assuming that the given layout is described by a rectangular area in the plane and with four vertices $(0,0)$, $(u,0)$, $(0,v)$ and (u,v) . There are n rectangular demand

facilities with fixed locations in the layout. To be determined are the location of a supply facility and an I/O point on its perimeter. Further, the location of an I/O point has to be determined for each of the demand facilities.

The objective of the model is to minimize the total transportation (i.e., material handling) costs. We assume that the model follows the L_1 -metric, also referred to as the Manhattan or Rectilinear metric. Such an assumption is reasonable when layout problems are concerned, as it faithfully models aisle structures, storage racks, etc. Assume now that two points X and Y represent two different locations in our layout of the shop floor. Given that, we define a *path* between X and Y as any continuous sequence of line segments, each of which is parallel to either the abscissa or the ordinate, that connects X and Y ; the *length* of such a path is simply the sum of the lengths of its individual component line segments. Such a path is called *feasible* only if it does not properly intersect any of the travel barriers (given by demand and the supply facilities). Finally, the length of a shortest feasible path between X and Y is referred to as the *distance* between X and Y , and denoted by $d_1(X, Y)$.

Next, suppose that the demand facility $F_i=(x_i, y_i, u_i, v_i)$ has four vertices (x_i, y_i) , (x_i+u_i, y_i) , (x_i, y_i+v_i) , and (x_i+u_i, y_i+v_i) for $i=1, 2, \dots, n$ and supply facility F_0 has four vertices (x_0, y_0) , (x_0+u_0, y_0) , (x_0+u_0, y_0+v_0) , and (x_0, y_0+v_0) . Then our problem can be formulated as the following:

$$\begin{aligned} & \text{minimize } \sum_{i=1}^n w_i d_1(X_0 = (x'_0, y'_0), X_i = (x'_i, y'_i)) \\ & \text{subject to } x_i \leq x'_i \leq x_i + u_i \text{ for } i = 1, \dots, n, \quad (1) \\ & \quad y_i \leq y'_i \leq y_i + v_i \text{ for } i = 1, \dots, n, \\ & \quad X_0 \in A \cap R, \end{aligned}$$

where w_i is the unit distance cost for material supplied to demand facility F_i ; A is the feasible region such that F_0 does not physically overlap with any demand facility; R is the set of points on the perimeters of F_0 ; x_i , y_i , u_i , and v_i are given constants; and x'_i and y'_i are decision variables, for $i=0, \dots, n$ and represent the location of the I/O point on the i th demand facility respectively. Intuitively, X_i^* , the optimal solution to (1), will satisfy (i) $d_1(X_i^*, F_0) \leq d_1(X_i, F_0)$ for any $X_i \in F_i$ and (ii) be located on the perimeter of F_i .

3. Solution procedure for a fixed supply point

This section addresses the most basic variant of the model in which the supply facility is a point (called *supply point*) whose coordinates are known and fixed. The objective then is to find optimal locations for the I/O points associated with each of the demand facilities; this can be formulated as

$$\begin{aligned} & \text{minimize } \sum_{i=1}^n w_i d_1(X_0 = (x_0, y_0), X_i = (x'_i, y'_i)) \\ & \text{subject to } x_i \leq x'_i \leq x_i + u_i \text{ for } i = 1, \dots, n, \quad (2) \\ & \quad y_i \leq y'_i \leq y_i + v_i \text{ for } i = 1, \dots, n. \end{aligned}$$

where x_0 , y_0 , x_i , y_i , u_i , and v_i are given constants and x'_i and y'_i are decision variables, for $i = 1, \dots, n$. Note that (2), in turn, can be decomposed into n subproblems of the type

$$\begin{aligned} & \text{minimize } d_1(X_0 = (x_0, y_0), X_i = (x'_i, y'_i)) \\ & \text{subject to } x_i \leq x'_i \leq x_i + u_i \quad (3) \\ & \quad y_i \leq y'_i \leq y_i + v_i \end{aligned}$$

Since d_1 depends highly on the layout structure a direct solution of (3) is impractical. Hence, we now introduce the concept of *probe termination points*.

Given a point X_0 in the layout, a *probing procedure* starts from this point going up (and down) vertically and right (and left) horizontally until the procedure is forced to terminate at the first barrier (facility) encountered or at the bounding rectangle's perimeter. If the termination point, say X_t , is in a perimeter of a facility, then X_t is said to be a probe termination point of X_0 . For example, Fig. 1 illustrates a case where X_{t1} , X_{t2} , X_{t3} , and X_{t4} are probe termination points of X_0 . We record the probing procedure from X_0 by dashed lines and call them *node traversal lines*. We define the *probe termination points of the layout* as the probe termination points of all vertices of the facilities (including the supply facility) and *the probe termination points of a facility F* as the probe termination points of the layout which are located on the perimeter of facility F .

Lemma 1. *The I/O candidates of a facility F are its vertices and probe termination points.*

Proof. We first consider the probe termination points on F created by the vertices of the other demand facilities. As illustrated in Fig. 2, the node traversal lines which cause probe termination points on F and the node traversal lines of the four vertices of facility F partition the layout into cells. We say a cell is adjacent to F if they share a segment. In our example, B_2 is adjacent to F but B_1 is not adjacent to F .

Now, consider the location of the supply point. If it is located in a cell that is adjacent to facility F (e.g. C_1), then by the definition of probe termination point, we must have a candidate I/O point caused by the probing procedure from the supply point. Also, this point is obviously the optimal I/O point of facility F . Thus the lemma holds.

If the supply point is located in a cell which is not adjacent to facility F , then the shortest feasible path to F will either end at one of F 's vertices (e.g. C_2) or be coincident with one of the node traversal lines incident on F (e.g. C_3). If the shortest feasible path reaches F at some vertex, then the lemma holds because the four vertices are candidates for the optimal I/O point. Finally, when the shortest feasible path has to be coincident with (or meet) one of the node traversal lines incident on F , then there must be a shortest path that does not have to cross the node traversal line. This is because the path, continuing from the intersection then following the node traversal line to reach F at the corresponding candidate, has a shorter distance than others which cross the line. It completes the proof. ■

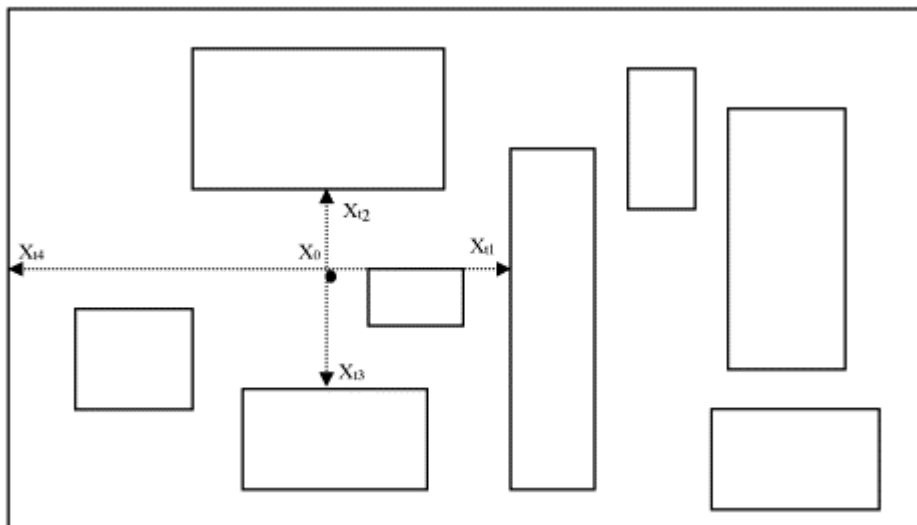

Fig. 1. The probe termination points.

The cell in which the supply facility is located is called the *supply cell*. In Fig. 2, for instance, if the supply point is C_2 then B_1 is the supply cell. On the other hand, if C_3 is the supply point then B_3 is the supply cell. We can now narrow down the candidates of the optimal I/O point of the facility F as follows.

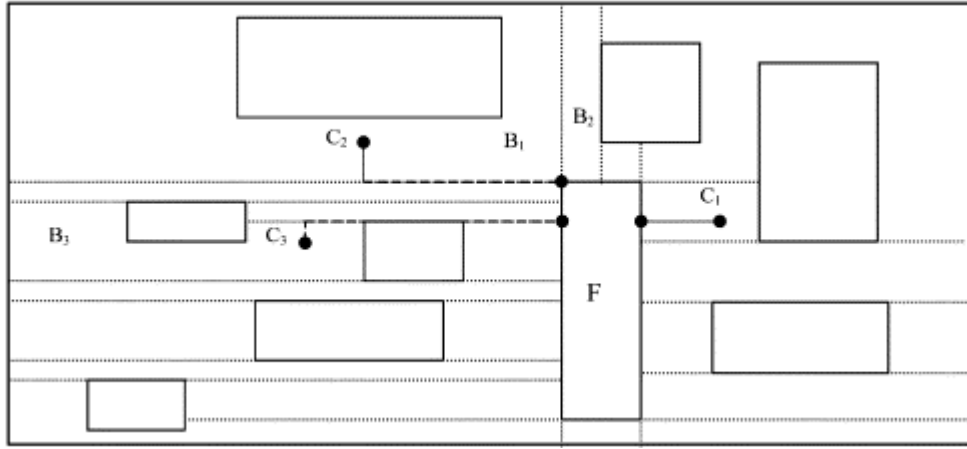

Fig. 2. Partition cells of the layout corresponding to facility F .

Lemma 2. *The optimal I/O candidates of a facility F are its vertices and probe termination points corresponding to the node traversal lines that are either the perimeters of the supply cell (if the supply cell is not adjacent to F), or within the supply cell (if the supply cell is adjacent to F).*

Proof. The proof follows from Lemma 1. ■

Next, we introduce the notion of L_1 -visible points and work on the characterizations of the shortest feasible paths between any two given points. Two points, $X_1=(x_1,y_1)$ and $X_2=(x_2,y_2)$, are said to be L_1 -visible if: (i) segments $(x_1,y_1)-(x_2,y_1)$ and $(x_2,y_1)-(x_2,y_2)$ do not properly intersect any facility, or (ii) segments $(x_1,y_1)-(x_1,y_2)$ and $(x_1,y_2)-(x_2,y_2)$ do not properly intersect any facility, or (iii) both (i) and (ii). It is clear that the length of the shortest feasible path which connects two L_1 -visible points X_1 and X_2 is $d_1(X_1,X_2)=|x_1-x_2|+|y_1-y_2|$. Given this definition, Lemma 3 will establish that:

Lemma 3. *For any two points $X_1=(x_1,y_1)$ and $X_2=(x_2,y_2)$ in the layout, it can be assumed that one and only one of the following conditions holds:*

- (i) $X_1=(x_1,y_1)$ and $X_2=(x_2,y_2)$ are L_1 -visible and the length of the shortest visible path between them is $d_1(X_1,X_2)=|x_1-x_2|+|y_1-y_2|$.
- (ii) $X_1=(x_1,y_1)$ and $X_2=(x_2,y_2)$ are not L_1 -visible and there exists at least one feasible shortest path between them containing a sequence of L_1 -visible vertices.

Proof. The proof follows from Theorems 1 and 2 of Larson and Li [16].

In order to determine the optimal I/O points of facility F , we create a network, N_F in which the nodes are given by the supply point, the candidate I/O points of F , and the vertices of the other demand facilities. An edge in N_F exists for every pair of L_1 -visible nodes except when neither of the nodes to be connected by an edge are vertices of the other demand facilities. The edge length is the L_1 distance between the nodes it connects. We can then prove Lemma 4.

Lemma 4. *The length of the shortest path for any pair of nodes in network N_F is their d_1 distance (length of the shortest feasible path between them) in the given layout.*

Lemma 4 can now be used to find the optimal I/O point for facility F as follows: let the supply point be the origin node and the I/O candidates of facility F be possible destination nodes. Now apply a shortest path algorithm to determine the shortest paths between the origin and the set of destination points (e.g. Dijkstra, [18]). Lemma 4 guarantees that the length of the shortest path between the origin and the destination in the network is the length of the shortest feasible path from the supply point to the candidate. The candidate corresponding to

the minimum length of the shortest feasible path is the optimal I/O point. Thus the algorithm for finding the optimal I/O points for the demand facilities is as follows:

Algorithm 1. For each demand facility F repeat Steps 1 and 2. *Step 1:* Perform the probing procedure for the supply point and all vertices of the other demand facilities to determine the set of candidates for the optimal I/O point of F . Create network N_F . *Step 2:* Determine the lengths of the shortest paths between the supply facility and each I/O candidate. The candidate corresponding to the minimal path length is the optimal I/O point of F .

To determine the time complexity of Algorithm 1, note that the probing procedure of Step 1 is an $O(n)$ procedure since probing has to be executed for the supply point and two opposite vertices of each demand facility for a total of $(2n+1)$ points. Creation of N_F is $O(n^2)$ calculations since there are at most $4(2n+1)$ nodes and each pair of nodes have to be checked if they are L_1 -visible. Step 2 depends on the shortest path algorithm employed; for instance, a straightforward application of Dijkstra's algorithm can be done with $O(n^2)$ time complexity. Since the shortest path algorithm is executed the between the supply point and each of the candidate I/O points, the complexity of Step 2 is $O(n^3)$. Steps 1 and 2 need to be repeated for n facilities. Therefore the worst-case time complexity of Algorithm 1 is $O(n^4)$.

4. Simultaneous location of supply point and I/O points of fixed demand facilities

In the previous section, we assumed that the location of the supply point is fixed. In this section, we relax this constraint and allow the supply point to be located in a given rectangular feasible region that does not overlap with any existing facility. Since the shortest feasible paths depend highly on the location of the supply point, we cannot divide the problem into n subproblems as we did in the previous section. Instead, we approach this problem by identifying a finite number of candidate points in the constrained region where the optimal location of the supply point lies and creating a grid as follows.

Assume that the rectangular feasible region is given by the shaded facility shown in Fig. 3. If we conduct probing procedures from the vertices of the demand facilities through the shaded feasible region from all direction, the traversal lines divide the feasible placement region into a number of rectangular cells. Note that by the way a cell is constructed, no node traversal line is within the interior of the cell.

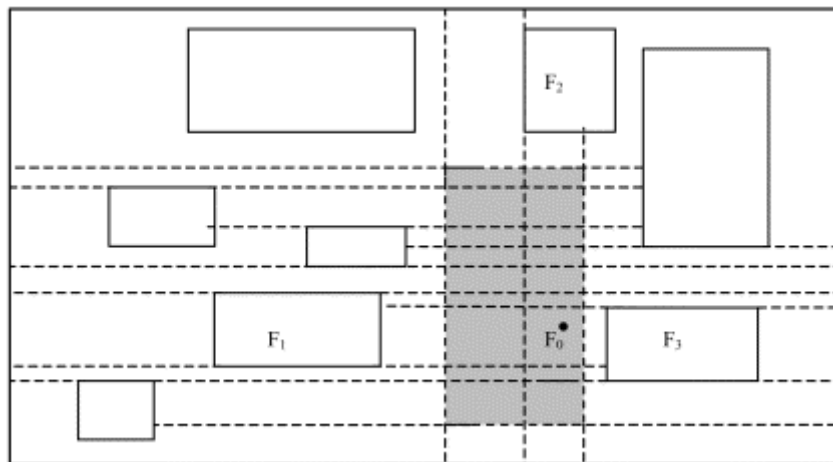

Fig. 3. Cells of the feasible region.

We first focus on the cell in which the supply point is allocated. As shown in Fig. 4, the cell can be partitioned into four blocks by segments $A-B$ and $C-D$. For a specific demand facility F_i , we define a function $f_i : [A-B] \rightarrow \mathcal{R}$, where $[A-B]$ is the set of points located on segment $A-B$ and \mathcal{R} represents the set of real numbers. This function maps the supply point, F_0 , in $[A-B]$ to the length of the shortest feasible path from F_0 to facility F_i .

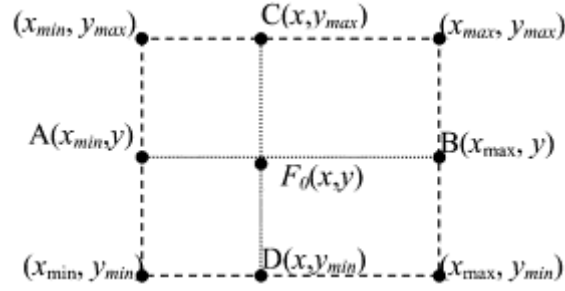

Fig. 4. A cell in the feasible region.

Note that, at least one of the following two cases has to be true: (i) the shortest path from F_0 to F_i is a straight line probing from F_0 horizontally (e.g. in Fig. 3, F_1 and F_3) or vertically to F_i (e.g. F_2); (ii) there is a shortest path between F_0 and F_i that passes through either A or B (e.g. all demand facilities except F_1 , F_2 and F_3). In case (i), f_i is either constant (e.g. f_2) or monotone (e.g. f_1 and f_3) as F_0 moves horizontally. Therefore, it is a special case of a concave function. In case (ii), we argue that f_i is also a concave function as follows.

Suppose the length of segment $[A-B]$ is l , the length of the shortest feasible path from A to F_i is l_A and the length of the shortest feasible path from B to F_i is l_B . Let $m=(l_B - l_A + l)/2$ and $P=(x_{\min} + m, y)$ be a point on segment $[A-B]$. From the definition of P , it is easy to show that for those points between A and P , the shortest path passes A to reach F_i and for those points between P and B , the shortest path passes B to reach F_i . Also, the length of the shortest path from point P to facility F_i , which either passes through A or B , is $(l_B + l_A + l)/2$. Furthermore, the f_i value increases linearly as the point moves from A to P and reaches the maximum at $f_i(P)=(l_B + l_A + l)/2$. After reaching P , the function starts decreasing linearly and reaches another local minimum at B . This shows that f_i is a concave function. This desirable property leads us to the following lemma which helps delineate a finite number of candidate points in the constrained region.

Lemma 5. *There is at least one optimal supply point located in the corner of a cell.*

Proof. We first consider the possibility of locating the supply point on segment $A-B$. For any F_0 on $A-B$, the objective value of F_0 is $\sum_i f_i(F_0)$. Since f_i is concave, the objective function, which is a sum of concave functions, is also concave. Hence the function is minimized at either A or B . If A is the optimal location on segment $[A-B]$, we follow the argument above on segment $(x_{\min}, y_{\min})-(x_{\min}, y_{\max})$, and conclude either (x_{\min}, y_{\min}) or (x_{\min}, y_{\max}) has a better solution than A . Similarly, if B is the optimal location on $[A-B]$, then either (x_{\max}, y_{\min}) or (x_{\max}, y_{\max}) has a better solution than B .

We can now provide a solution to the location of the supply point within a rectangular feasible region as follows. Given a feasible region, we divide the region into a number of rectangular cells by node traversal lines (similar to Fig. 3). By Lemma 5, the finite set of candidate points consists of the corners of the cells. Given the way the traversal lines are created, we have at most $2n$ horizontal lines and $2n$ vertical lines. Hence, the number of candidate is no more than $4n^2$. We then apply Algorithm 1, with complexity $O(n^4)$, to determine the objective value for each candidate. The candidate point with the minimal objective value is the optimal location for our supply point and the complexity of this algorithm is $O(n^6)$.

Note that this algorithm can be easily generalized to apply to the case where the supply point is required to be located anywhere in the layout, as long as it does not overlap with any demand facility. In this case, the candidate points for the supply point are all grid points that represent the intersection of two node traversal lines of the vertices of the demand facilities.

5. Finite dimensional rectangular-shaped supply facility

In this section, we relax the assumption that the supply facility is infinitesimally small and discuss the case where it is finite sized, given by a rectangle. This problem is more difficult since the supply facility is no longer

infinitesimal and itself causes a barrier in the layout. Savas et al. [14] have recently considered a problem where they locate a single barrier in the presence of other barriers to rectilinear travel. They examine the barrier location problems with single and multiple I/O points as well as fixed and non-fixed I/O point locations. The difference between their paper and ours is that they assume fixed I/O points on the demand barriers. By contrast, ours is a more general model, where the locations of the I/O points on the demand facilities are also decision variables.

Note that, from Section 3, we know the optimal I/O point of a demand facility must be an intersection of node traversal lines of the vertices of the demand facilities and of the supply facility. If we form a grid by node traversal lines of the vertices of the demand facilities, this grid is a special case of the corresponding grid provided by Savas et al. Thus, we will exploit the following results developed in Savas et al. (1) The only points we need to consider as candidate locations for the I/O point of the supply facility are the intersections of node traversal lines. (2) If the I/O point is fixed and the supply facility is free to move as long as the I/O point remains on its boundary, the optimal location of the supply facility must be such that the sides of the facility coincide with node traversal lines. (3) If it is feasible to locate the supply facility with the I/O point at the corner that coincides with the optimal location for the infinitesimal point location problem, then this is also the optimal location for the barrier location problem and the objective values are the same; such an infinitesimal point is called *corner feasible*.

The algorithm below determines the optimal location of the supply facility, its I/O point, and I/O points of the demand facilities.

Algorithm 2.

Step 1: Label each intersection of node traversal lines of the layout as a fixed supply point. Apply Algorithm 1 to each intersection to determine the shortest paths to demand facilities and sum the lengths of the shortest paths.

Step 2: Sort the values from Step 1 in an increasing order: f_1, f_2, \dots, f_k . Let i denote the intersection corresponding to f_i . Let $i = 1$ and $f_{k+1} = \infty$.

Step 3: For intersection i , if i is corner feasible, $f'_i = f_i$. Otherwise, assume the supply facility is free to move as long as i remains on its boundary, determine the finite number of locations of the supply facility such that the sides of the facility coincide with node traversal lines. Label the one with best objective function value as f'_i .

Step 4: If $f'_i \leq f_{i+1}$, the minimal f'_k ($k=1, \dots, i$) is the optimal objective value and node k is the optimal location of the I/O point of the supply facility. Also, the supply facility associated with the f'_k value is the optimal location of the supply facility. Otherwise, $i = i + 1$ and go to Step 3.

Step 5: With the optimal locations of the supply facility and its I/O point from Step 4, apply Algorithm 1 to determine the optimal I/O points of the demand facilities.

To understand the working of Algorithm 2, note that it first labels the intersections of node traversal lines; these intersections are actually the candidates for the optimal I/O point of the supply facility (see property (1)). As mentioned earlier, this step requires $2n$ probing procedures and creates at most $4n^2$ candidates. Algorithm 1, with complexity $O(n^4)$, is then applied to calculate the total length of the shortest paths from the interaction to the demand facilities. The value is denoted by f_i and f_i is a lower bound of the objective value if i is the I/O point of the supply facility. We have at most $O(n^2)$ number of f_i 's and hence, we need $O(n^6)$ calculations to determine them.

Given the I/O point for the supply facility located in i , Step 3 first checks if i is corner feasible. Otherwise, we should determine all the possible locations of the supply facility that may be optimal (see property (2)) and label the one with best objective function value as f'_i . Note that f_i is a lower bound of f'_i and if i is corner feasible then $f'_i = f_i$ (see property (3)).

Since f_i is a lower bound of f'_i and f_i is ordered increasingly, as $f'_i \leq f_{i+1}$ (assume $f_{k+1} = \infty$), the minimal f'_k ($k = 1, \dots, i$) is the optimal objective value and the conclusion in Step 4 follows. Since we have at most $4n^2$ candidates,

the complexity of the sorting procedure to determine f_i' is $O(n^2 \log(n))$. Step 5 is of complexity $O(n^4)$. Thus, the complexity of Algorithm 2 is $O(n^6)$.

6. Efficiency improvement by dominance rules

Recall from Section 3 that the network includes an edge between any pair of L_1 -visible nodes. Consequently, the number of edges may be very large. Here, we develop dominance rules to eliminate some edges and help reduce the network size. While these dominance rules do not affect the worst-case time complexity of the two algorithms, their use in practice may speed up execution.

To develop these dominance rules, we classify the demand facilities into the following four sets based on their relationship with the probe termination rectangle (refer to Fig. 5):

S_1 : This set contains only one facility on which X_i is located.

S_2 : This set contains facilities which (i) lie outside the probe termination rectangle or (ii) overlap with the probe termination rectangle with a segment, but exclude the facilities on which X_i and its probe termination points are located (e.g. $F_3, F_4, F_8,$ and F_9).

S_3 : This set contains facilities which contain a probe termination point and overlap with the probe termination rectangle with a segment (e.g. $F_1, F_5, F_6,$ and F_{11}).

S_4 : This set contains facilities which lie outside the probe termination rectangle and do not overlap with the probe termination rectangle (e.g. F_2 and F_{10}).

Based on these set definitions, the following rules can be prescribed to determine the necessity of creating an edge between a pair of L_1 -visible vertices X_i-X_j :

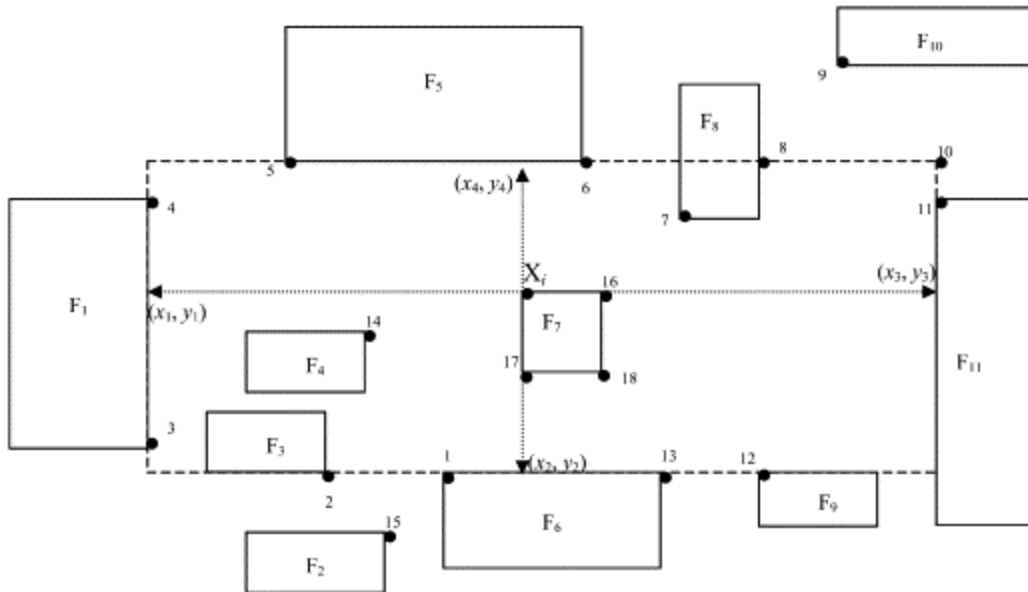

Fig. 5. The probe termination rectangle of X_i .

Rule 1: X_j is a vertex of an S_1 -type facility: in this case, X_i and X_j are located on the same facility. X_i-X_j is created only if X_j is one of the two closest vertices of X_i .

Rule 2: X_j is a vertex of an S_2 -type facility: if the vertex of the facility, which is closest to X_i , is L_1 -visible from X_i , then X_i-X_j is created only if X_j is the closest vertex to X_i . Otherwise, check if X_j is the farthest vertex from X_i . If it is not, X_i-X_j is created.

Rule 3: X_j is a vertex of an S_3 -type facility: X_i-X_j is created only if X_j is on the perimeter of the probe termination rectangle.

Rule 4: X_j is a vertex of an S_4 -type facility: X_i-X_j is not needed.

For example in Fig. 5, we need only create the edges connecting node X_i and nodes 1, 3, 4, 5, 6, 7, 11, 12, 13, 14, 16 and 17. This reduces the number of edges from 36 to 12. However, what remains is to show that by applying the four rules above, the new network created dominates the original network N_F proposed in Section 3; this is accomplished in the following lemma.

Lemma 6. *Any two L_1 -visible vertices in the layout are connected by a path that consists of a sequence of edges created by rules 1–3, and the length of the path is the L_1 -distance between the two vertices.*

Proof. Suppose the two vertices are X_i on facility F_i and X_j on facility F_j , we prove this lemma by creating a path that satisfies the lemma. We condition the proof on whether or not X_j is within the probe termination rectangle of X_i . *Case I:* X_j is within the probe termination rectangle of X_i : in case that X_j is the closest vertex of F_j to X_i , then by Rule 2, edge X_i-X_j is created. If X_j is neither the farthest nor the closest vertex of F_j to X_i , by Rule 2, edge X_i-X_k is created. If X_j is the farthest vertex of F_j to X_i , then we can first apply Rule 2 on X_i and then Rule 1 on X_1 , the desired sequence of edges is created (see Fig. 6). *Case II:* X_j is not within the probe termination rectangle of X_i : since X_j is L_1 -visible to X_i , there is a point, say X_k , such that edges X_i-X_k and X_k-X_j do not encounter any obstacles. Without loss of generality, we display the situation in Fig. 7. Then, by the properties that X_j is not within the probe termination rectangle of X_i and edge X_i-X_k does not encounter any obstacles, edge X_k-X_j must be partly located inside the probe termination rectangle of X_i . Let X_l denote the vertex which satisfies the following four properties associated with X_i and X_j : (i) located in the upper-right corner of the probe termination rectangle; (ii) connected to X_i by one of the four rules; (iii) located in the left hand side of the edge X_k-X_j ; and (iv) no other vertices which connect to X_i and locate between the vertical line passing X_l and edge X_k-X_j . With these properties, X_i can reach edge X_k-X_j horizontally without encountering any obstacles. To see this, if the probing process is terminated by a facility before it reaches edge X_k-X_j , then there must be a vertex on the facility which connects to X_i (by Rule 2) and located between the vertical line passing X_l and edge X_k-X_j . This contradicts (iv) according to the way we define X_l . We now focus on the L_1 -visible path is $X_i-X_{k+1}-X_j$. If X_j is within the probe termination rectangle of X_{k+1} then the desired path exists by the argument of Case I. On the other hand, if X_j is not within the probe termination rectangle of X_{k+1} , then let X_{l+1} be the vertex which satisfies the four properties proposed above associated with X_{k+1} and X_j (we may perform this procedure since $X_i-X_{k+1}-X_j$ is not properly intersected). Again, if X_j is within the probe termination rectangle of X_{l+1} then the desired path exists by the argument of Case I. Otherwise, repeat the procedure and finally a path that connects X_i and X_j is created since the distance between X_i and X_j is finite. Note that since the vertex we pick to create the path is always on the upper-right corner of the previous vertex, it is clear that the length of the path is equal to the L_1 -distance of X_i and X_j . ■

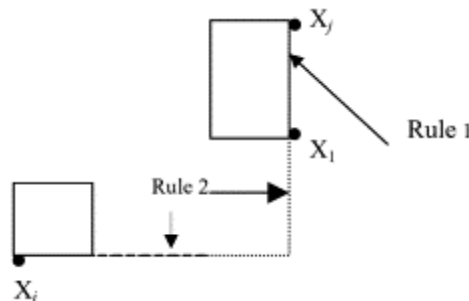

Fig. 6. X_j is within the probe termination rectangle of X_i .

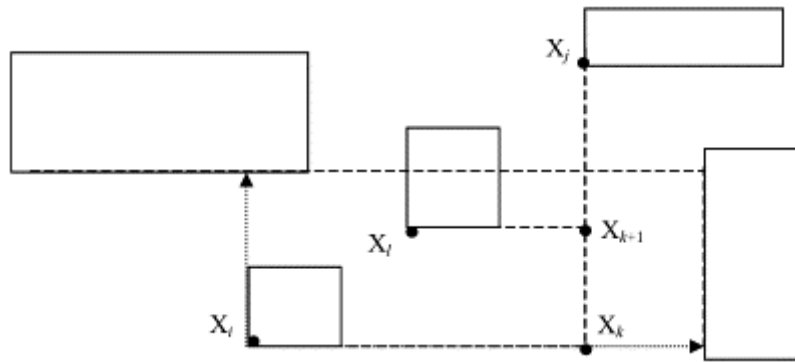

Fig. 7. X_j is not within the probe termination rectangle of X_i .

7. Conclusion

This paper extends the existing literature on the location of facilities in the presence of forbidden regions within the context of a layout problem. The salient contribution of this paper is the formulation and solution of a model that combines the twin problems of Minisum location of a (possibly finite-sized) supply facility with that of the location of i/o points on the demand and supply facilities. Methodologically, the principal solution technique employed is to reduce the continuous location problems to discrete ones by characterizing the finite sets of points that are guaranteed to contain the optimal locations. Using this technique, several, progressively more complex variants of the model are presented and polynomial time solution algorithms are developed for each case.

We believe that this paper opens up new avenues for simultaneous location and I/O point selection in facilities layout. Further work could include non-rectangular (convex or non-convex) supply and demand facility shapes by using the theory developed by Batta et al. [10]. Another interesting avenue is the location of more than one supply facility concurrently, which is more general and practical.

Acknowledgements

Rakesh Nagi was supported in part by the National Science Foundation, via Grant No. DMI-9800429. This support is gratefully acknowledged.

References:

- [1] H. Co, A. Wu and A. Riesman, A throughput maximizing facility planning and layout model. *International Journal of Production Research* **27** 1 (1989), pp. 1–12.
- [2] P.D. Dowling, Floor layouts using a multifacility location model. *Naval Research Logistics* **37** 6 (1990), pp. 945–952.
- [3] A. Houshyar and L.F. McGinnis, A heuristic for assigning facilities to locations to minimize WIP travel distance in a linear facility. *International Journal of Production Research* **28** 8 (1990), pp. 1485–1498.
- [4] K.H. Kim, Positioning of automated guided vehicles in a loop layout to minimize the mean vehicle response time. *International Journal of Production Economics* **39** 3 (1995), pp. 201–214.
- [5] P.S. Welgama and P.R. Gibson, A construction algorithm for the machine layout problem with fixed pick-up and drop-off points. *International Journal of Production Research* **31** 11 (1993), pp. 2575–2590.
- [6] Francis RL, McGinnis Jr LF, White JA. Facility layout and location: an analytical approach. Englewood Cliffs, NJ: Prentice-Hall, 1992.
- [7] Katz IN, Cooper L. Facility location in the presence of forbidden regions, II: Euclidean distance and several forbidden circles. Technical Report OREM 79006, Department of Operations Research and Engineering Management, Southern Methodist University, Dallas, TX, 1979.
- [8] Katz IN, Cooper L. Facility location in the presence of forbidden regions, III: l_p -distance and polygonal forbidden regions. Technical Report OREM 79011, Department of Operations Research and Engineering Management, Southern Methodist University, Dallas, TX, 1979.

- [9] I.N. Katz and L. Cooper, Facility location in the presence of forbidden regions, I: formulation and the case of Euclidean distance with one forbidden circle. *European Journal of Operations Research* **6** (1981), pp. 166–173.
- [10] R. Batta, A. Ghose and U.S. Palekar, Locating facilities on the Manhattan metric with arbitrarily shaped barriers and convex forbidden regions. *Transportation Science* **23** 1 (1989), pp. 26–36.
- [11] S.E. Butt and T.M. Cavalier, An efficient algorithm for facility location in the presence of forbidden regions. *European Journal of Operational Research* **90** 1 (1996), pp. 56–70. 12.
- [12] H.W. Hamacher and S. Nickel, Restricted planar location problems and applications. *Naval Research Logistics* **42** 6 (1995), pp. 967–992.
- [13] J. Brimberg and G.O. Wesolowsky, Note: facility location with closest rectangular distances. *Naval Research Logistics* **47** (2000), pp. 77–84.
- [14] Savas S, Batta R, Nagi R. Finite-size facility placement in the presence of barriers to rectilinear travel. *Operations Research* 2001, in press.
- [15] Lozano-Perez T, Wesley M. An algorithm for planning collision-free paths among polyhedral obstacles. IBM Thomas J. Watson Research Center, RC 7171, June, 1978.
- [16] R.C. Larson and V.O.K. Li, Finding minimum rectilinear distance paths in the present of barriers. *Networks* **11** (1981), pp. 285–304.
- [17] R.D. Meller and K.Y. Gau, The facility layout problem: research and emerging trends and perspectives. *Journal of Manufacturing Systems* **15** 5 (1996), pp. 351–366.
- [18] E.W. Dijkstra, A note on two problems in connexion with graphs. *Numerische Mathematik* **1** (1959), pp. 269–271.
- [19] H. Alt and E. Welzl, Visibility graphs and obstacle-avoiding shortest paths. *Mathematical Methods of Operations Research* **32** 3–4 (1988), pp. 145–164.
- [20] R.C. Larson and G. Sadiq, Facility locations with the Manhattan metric in the presence of barriers to travel. *Operations Research* **31** (1983), pp. 652–669.

Vitae:

Shou-Jiun Wang received his Ph.D. in Operations Research from the Department of Industrial Engineering at the State University of New York at Buffalo in 2000. He is currently working as a Credit/Risk Analyst in First USA Bank. His research interests are in applied operations research.

Joyendu Bhadury is an Associate Professor of Quantitative Business Methods in the School of Business and Economics and also the Director of the Engineering Program at California State University-Hayward. He finished his Ph.D. in Management Science from University of Texas at Dallas in 1991 and subsequently taught at University of New Brunswick and State University of New York at Buffalo. His papers have appeared in journals such as INFORMS Journal of Computing, Journal of Regional Science, Social Choice and Welfare, Location Science and European Journal of Operational Research. His research interests are in Competitive Location Theory, Logistics Management and Applied Quantitative Management.

Rakesh Nagi is an Associate Professor of Industrial Engineering at the State University of New York at Buffalo. He obtained his Ph.D. from the University of Maryland at College Park in 1991. He is a recipient of IIE's Outstanding Young Industrial Engineer Award in Academia (1999), SME's Milton C. Shaw Outstanding Young Manufacturing Engineer Award (1999), and National Science Foundation's CAREER Award (1996). His papers have been published in journals including IIE Transactions, International Journal of Production Research, International Journal of Flexible Manufacturing Systems, Journal of Manufacturing Systems, Journal of Intelligent Manufacturing, Computer Integrated Manufacturing Systems, Annals of Operations Research, Computers in Operational Research, and Computers in Industrial Engineering. His recent research interests are in production systems design, production management, and agile and information-based manufacturing.