

Analyzing Split Channel Medium Access Control Schemes

Jing Deng, Yunghsiang S. Han, and Zygmunt J. Haas

J. Deng, Y. S. Han, and Z. J. Haas, "Analyzing Split Channel Medium Access Control Schemes," IEEE Transactions on Wireless Communications, vol. 5, no. 5, pp. 967-971, May 2006. DOI: [10.1109/TWC.2006.1633347](https://doi.org/10.1109/TWC.2006.1633347)

Made available courtesy of Institute of Electrical and Electronics Engineers: <http://www.ieee.org/>

***** (c) 2006 IEEE. Personal use of this material is permitted. Permission from IEEE must be obtained for all other users, including reprinting/ republishing this material for advertising or promotional purposes, creating new collective works for resale or redistribution to servers or lists, or reuse of any copyrighted components of this work in other works.**

Abstract:

In this work, we analyze and evaluate the maximum achievable throughput of split-channel MAC schemes that are based on the RTS/CTS (Ready-To-Send/Clear-To-Send) dialogue and that rely on pure ALOHA or on p-persistent Carrier Sensing Multiple Access (CSMA) contention resolution techniques. Our results show that, when radio propagation delays are negligible and when the pure ALOHA mechanism is used, then for a network with relatively large number of nodes, the maximum achievable throughput of the split-channel MAC schemes is lower than that of the corresponding single-channel MAC schemes. When the split-channel MAC schemes employ the p-persistent CSMA mechanism, then they out-perform the corresponding single-channel schemes when the maximum end-to-end propagation delays are at least 25% of the transmission time of the control packets on the single shared channel.

Index Terms: MAC, split channel, pure ALOHA, p-persistent CSMA, contention resolution, RTS/CTS dialogue, control channel, data sub-channel

Article:

I. INTRODUCTION

In wireless communication networks, Medium Access Control (MAC) schemes are used to control the access of active nodes to a shared channel. As the throughput of the MAC scheme may significantly affect the overall performance of a wireless network, to improve the performance, some researchers proposed to split, either in time or in frequency, the single shared channel into two sub-channels: a control sub-channel and a data sub-channel. With this arrangement, the control sub-channel is used for reservation of access to the data sub-channel over which the data packets are transmitted. One such a reservation technique, which we consider in this work, is implemented through the use of the RTS/CTS (Ready-ToSend/Clear-To-Send) dialogue. There have been many works using the split-channel approach [1]–[4]. For example, the available bandwidth was divided into three sub-channels in [1]. In [2], the authors employed a control channel and a data channel and proposed to use a partial pipelining technique to solve the problem of unbalanced channel separation. In [3] and [4], MAC protocol with power control was used with the split-channel approach.

In this work, we analyze the performance of a generic split-channel MAC scheme, which is based on the RTS/CTS dialogue. Two contention resolution techniques for the control sub-channel are studied: pure ALOHA and p-persistent Carrier Sensing Multiple Access (CSMA). For the pure ALOHA scheme, a ready node sends an RTS packet on the control sub-channel to reserve the use of the data sub-channel. When the RTS packet is received, the intended receiver replies with a CTS packet to acknowledge the successful reservation of the data sub-channel [5]. For the p-persistent CSMA scheme, RTS transmissions are allowed only at the beginning of every time slot. A ready node decides, with probability p , to send its RTS request when it does not sense a carrier on the control sub-channel. A CTS reply will be transmitted at the beginning of the next slot by the intended receiver, when the RTS packet is received successfully.

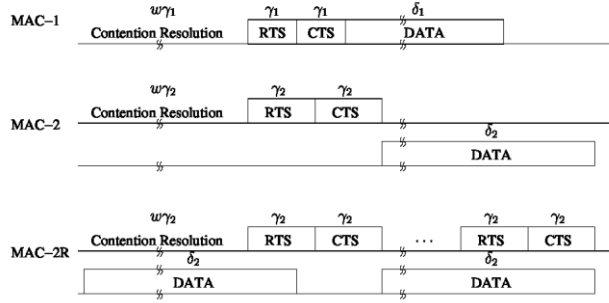

Fig. 1. Comparison of MAC-1, MAC-2, and MAC-2R

For notational convenience, we term the single-channel MAC scheme as MAC-1 and the split-channel MAC scheme as MAC-2. We further define MAC-2R as the MAC-2 scheme, but with parallel reservations; i.e., in the MAC-2R scheme, contention resolutions take place on the control sub-channel in parallel with the transmission of data packets on the data sub-channel. Figure 1 depicts an example of the operations of the MAC-1, the MAC-2, and the MAC-2R schemes.

It is rather simple to prove that the MAC-2R scheme out-performs the MAC-2 scheme [6]. Therefore, we focus on the comparison between the MAC-2R and the MAC-1 schemes. We make the following assumptions: The wireless communication network we study is assumed to be fully-connected¹ and the packet processing delays are negligible. We further assume that, when pure ALOHA contention resolution technique is used, the total traffic generated by active nodes (including retransmissions) is Poisson with aggregate arrival rate of A [data packets/sec], and that the radio propagation delay is negligible. When the p -persistent CSMA technique is employed, each node starts its RTS packet transmission with probability p , independent of all other nodes, after sensing an idle channel at the beginning of each time slot.

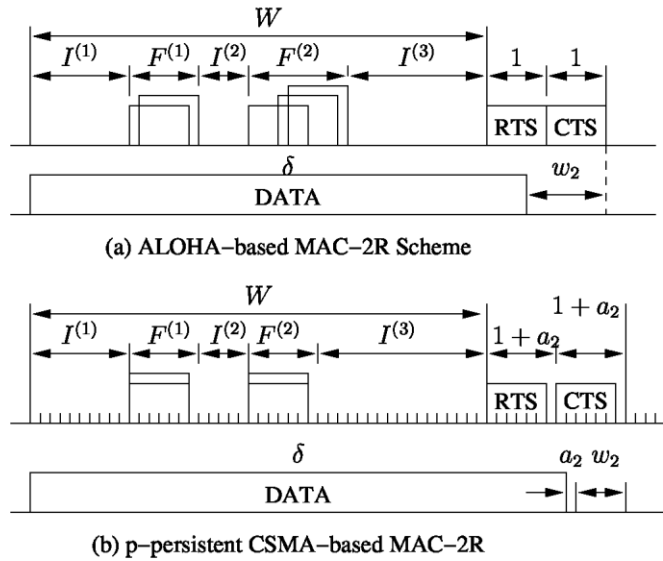

Fig. 2. An example of contention period in MAC-2R when ALOHA or p -persistent CSMA is employed

II. MAC SCHEMES BASED ON PURE ALOHA CONTENTION RESOLUTION

In our calculations of the throughput of the MAC-2R scheme, we normalize all variables with respect to the transmission time of a control packet in the MAC-2R scheme, which we define as γ_2 [seconds].

¹ Thus, the RTS/CTS dialogue is used as the mechanism to reserve the use of the channel.

As explained before, in the MAC-2R scheme, contention resolutions take place on the control sub-channel in parallel with the transmission of data packets on the data sub-channel. A contention resolution period (W) begins on the control sub-channel when the transmission of the data packet, for which the data sub-channel was reserved in the previous reservation period, starts on the data sub-channel. The contention period lasts until the start of the successful RTS/CTS dialogue (see Fig. 2a); thus, for infinite number of nodes² and according to [7], the Laplace transform of the duration of a contention period, $W^*(s)$, is:

$$W^*(s) = \frac{G e^{-G} [s + G e^{-(s+G)}]}{s^2 + sG[1 + e^{-(s+G)}] + G^2 e^{-2(s+G)}}, \quad (1)$$

where $G = \lambda\gamma_2$ is the combined rate of new arrivals and retransmissions. Consequently, the average duration of a contention period, $E[W]$, is:

$$\bar{w} = E[W] = -\left. \frac{\partial W^*(s)}{\partial s} \right|_{s=0} = \frac{1}{G} e^{2G} - 1. \quad (2)$$

It can be shown that $G = 0.5$ minimizes \bar{w} .

If we refer to S as the data-packet transmission time in units of control-packet transmission time, then $\delta = kr/(1 - r)$, where k is the ratio of data packet size (in bits) to the control packet size (in bits), and r is the ratio of the data rate of the control sub-channel to the data rate of the entire channel. In the MAC-2R scheme, when the value of W (say, w) satisfies $w + 2 < \delta$, the RTS/CTS dialogue succeeds before the end of the current data packet transmission on the data sub-channel. Thus, the next data packet transmission can start immediately after the current one ends. However, when $w + 2 > \delta$ (as shown in Fig. 2a), the data sub-channel will be idle for a non-negative period of time, until the contention resolution ends on the control sub-channel. We define this idle period of time as the waiting time on data sub-channel (w_2). The expected value of this waiting time, \bar{w}_2 , can be calculated as:

$$\bar{w}_2 = \int_{\delta-2}^{\infty} [w - (\delta - 2)] \cdot g(w) dw, \quad (3)$$

where $g(w)$ is the pdf of W .

Therefore, the throughput of the MAC-2R scheme can be expressed as

$$S_{2R}(r) = \frac{\delta}{\delta + \bar{w}_2} \cdot (1 - r) = \frac{1}{\frac{1}{1-r} + \frac{\bar{w}_2}{kr}}. \quad (4)$$

Note that, for fixed S and r , the throughput is maximized when w_2 is the smallest. Since /

$$\begin{aligned} \bar{w}_2 &= \int_0^{\infty} w g(w) dw - \int_0^{\delta-2} w g(w) dw - \\ &\quad (\delta - 2) \int_{\delta-2}^{\infty} g(w) dw \\ &= \bar{w} - \int_0^{\delta-2} w g(w) dw - (\delta - 2) \int_{\delta-2}^{\infty} g(w) dw, \end{aligned}$$

² Even though this result is derived by assuming infinite number of nodes, it is quite accurate for the 50-node scenario simulated later.

the $G = 0.5$ that minimizes \bar{w} is not necessary minimizing \bar{w}_2 .

In order to calculate \bar{w}_2 , we need to derive $g(w)$ explicitly, since \bar{w}_2 cannot be obtained by w alone, as indicated above. Instead of deriving a closed-form for $g(w)$, we use a numerical inversion of Laplace transforms, as presented in [8]. The value of $g(w)$ for a specified value of w can be estimated as follows. First, $g(w)$ can be represented by a sequence of discrete values, $s_n(w)$,

$$g(w) = s_n(w) - e_d, \text{ as } n \rightarrow \infty,$$

where $e_d = \sum_{i=1}^{\infty} e^{-iA} g((2i+1)t)$ is the discretization error. Then, $g(w)$ can be approximated by the $s_n(w)$ sequence as:

$$g(w) \approx s_n(w) = \frac{e^{A/2}}{w} \left\{ \frac{1}{2} W^* \left(\frac{A}{2w} \right) + \sum_{i=1}^n (-1)^i \text{Re}(W^*) \left(\frac{A + 2i\pi j}{2w} \right) \right\}, \quad (5)$$

where A is a positive constant such that $W^*(s)$ has no singular points on or to the right of the vertical line $s = A/(2w)$, and $\text{Re}(W^*)(s)$ is the real part of $W^*(s)$ when s is substituted by a complex number $x + yj$. In (5), n represents the degree of discretization of $g(w)$, i.e., the larger the value of n is, the more accurate is the estimation of $g(w)$ by $s_n(w)$. In the numerical results shown later, we found that $n = 30$ provides accurate enough results when compared with our simulation results.

If $|g(w)| \leq 1$, the error is bounded by ([8]):

$$|e_d| \leq \frac{e^{-A}}{1 - e^{-A}}.$$

When $A \geq 18.5$, the discretization error is 10^{-8} . The constant A can be further increased to improve the accuracy of the results.

Treating the packet transmission on the channel in the MAC-1 scheme as a renewal process, we can derive the throughput of the MAC-1 scheme as:

$$S_1 = \frac{k}{\bar{w} + 2 + k}, \quad (6)$$

where \bar{w} is given by (2).

III. MAC SCHEMES BASED ON p-PE1ZSISTENT CSMA CONTENTION RESOLUTION

Let the slot size of the p -persistent CSMA-based MAC-2R scheme be $\alpha_2 = \tau/\gamma_2$, which is the ratio of the maximum end-to-end signal propagation delay (τ) and the control packet transmission time (γ_2). Recall that each node starts to transmit with probability p , which is independent of other nodes, after sensing the channel being idle at the beginning of a slot. Since collision detection mechanism is not employed, an unsuccessful transmission period lasts $1 + \alpha_2$ unit time (again, we normalize all variables with respect to γ_2).

According to [7], the distribution of the contention resolution period, W (see Fig. 2b), is:

$$\Pr\{W = na_2 + \ell(1 + a_2)\} = U \binom{n + \ell}{\ell} E^n (1 - U - E)^\ell,$$

for $n, \ell = 0, 1, 2, \dots$, and

$$E[W] = \frac{\alpha_2(1-U) + (1-U-E)}{U}, \quad (7)$$

where

$$E = (1-p)^N, U = N_p(1-p)^{N-1}, \quad (8)$$

and N is the total number of nodes in the network. In the MAC-2R scheme, when the value of W (say, w) satisfies $w + 2(1 + \alpha_2) \leq \delta + \alpha_2$, the RTS/CTS dialogue succeeds before the end of the current data packet transmission on the data sub-channel. Thus, the next data packet transmission can start immediately after the current one ends. However, when $w + 2(1 + \alpha_2) > \delta + \alpha_2$, the data sub-channel will be left idle for a period of time, w_2 . The expected value of this waiting time (\bar{w}_2) can be calculated as follows (we define $\delta' = \delta - 2 - \alpha_2$). When $\delta' \leq 0$,

$$\bar{w}_2 = \sum_{w \geq 0} [w - \delta'] \cdot g(w) = \frac{\alpha_2(1-U) + (1-U-E)}{U} - \delta'.$$

When $\delta' > 0$,

$$\begin{aligned} \bar{w}_2 &= \sum_{w > \delta'} (w - \delta') \cdot g(w) \\ &= U \sum_{m = \left\lceil \frac{\delta'}{1+\alpha_2} \right\rceil}^{\left\lfloor \frac{\delta'}{\alpha_2} \right\rfloor - 1} \sum_{\ell = \lceil \delta' - m\alpha_2 \rceil}^m F(m, \ell) + \\ &\quad (1-U)^{\left\lfloor \frac{\delta'}{\alpha_2} \right\rfloor} \left(\alpha_2 \left\lfloor \frac{\delta'}{\alpha_2} \right\rfloor + \alpha_2 \cdot \frac{1-U}{U} - \delta' \right) + \\ &\quad (1-U-E)(1-U)^{\left\lfloor \frac{\delta'}{\alpha_2} \right\rfloor - 1} \left(\left\lfloor \frac{\delta'}{\alpha_2} \right\rfloor + \frac{1-U}{U} \right), \end{aligned}$$

where $\lceil x \rceil$ returns the smallest integer that is not smaller than x and

$$F(m, \ell) = (m\alpha_2 + \ell - \delta') \binom{m}{\ell} E^{m-\ell} (1-U-E)^\ell.$$

Similarly to (4), the throughput of the MAC-2R scheme can be expressed as:

$$S_{2R}(r) = \frac{\delta}{\delta + \alpha_2 + \bar{w}_2} \cdot (1-r) = \frac{1}{\frac{1}{1-r} + \frac{\bar{w}_2 + \alpha_2}{kr}}. \quad (9)$$

Note that the control sub-channel is now a CSMA channel regardless of the state of the data sub-channel. As in [7], we calculate p_2^\dagger , which satisfies

$$(\alpha_2 + 1)(1 - Np_2^\dagger) = (1 - p_2^\dagger)^N, \quad (10)$$

so that the control sub-channel can generate a successful RTS/CTS dialogue as soon as possible after the data channel is open for reservation.³ Thus, E and U can be calculated according to (8), where p is substituted by p_2^\dagger .

In the MAC-1 scheme, the renewal cycle to transmit one data packet includes the contention resolution period, the transmission time of the RTS and the CTS packets followed by two propagation delays, and the transmission time of the data packet followed by one propagation delay. Thus, the throughput of the MAC-1 scheme is:

$$S_1 = \frac{k}{\bar{w} + 2 + k + 3\alpha_1} = \frac{k}{\frac{\alpha_1(1-U) + (1-U-E)}{U} + 2 + k + 3\alpha_1},$$

where $\alpha_1 = \tau/\gamma_1$ and γ_1 is the transmission time of a control packet in the MAC-1 scheme. When p is set to p_1^\dagger , which satisfies

$$(a_1 + 1)(1 - Np_1^\dagger) = (1 - p_1^\dagger)^N, \quad (11)$$

the p -persistent CSMA-based MAC-1 scheme has the optimal throughput. Thus, E and U should be calculated according to (8), where p is substituted by p_1^\dagger .

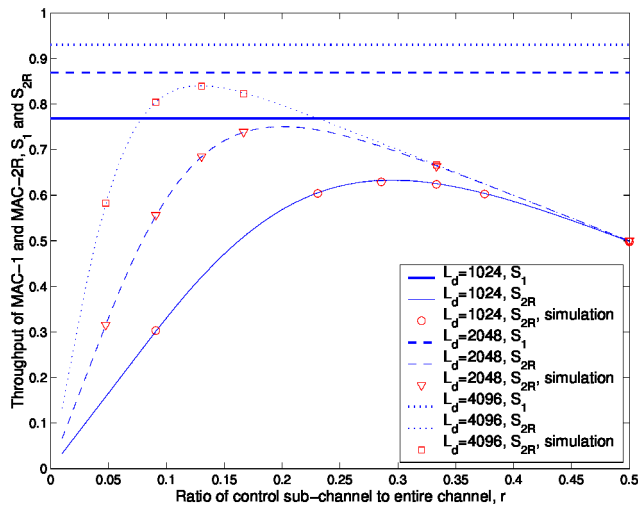

Fig. 3. Throughput comparisons between MAC-1 and MAC-2R when $G = 0.5$ (pure ALOHA-based)

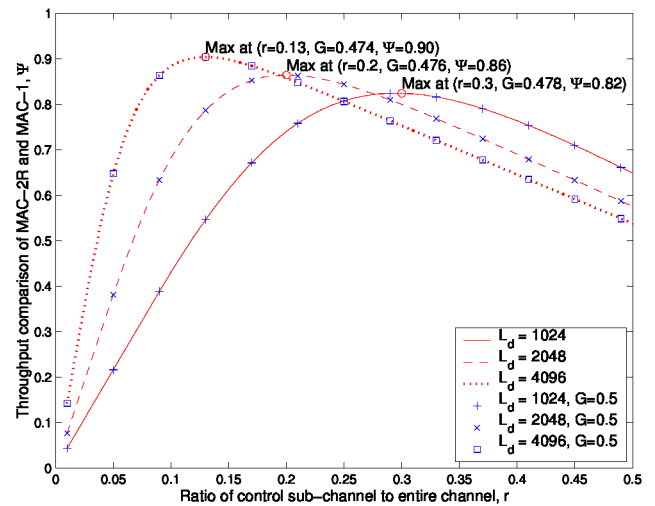

Fig. 4. Throughput comparisons between MAC-1 and MAC-2R with optimum traffic load, G (pure ALOHA-based)

³ Note that p_2^\dagger only minimizes the average contention resolution periods, W , but it may not be the optimum value that minimizes the average waiting time on the data sub-channel, w_2 . Therefore, p_2^\dagger may not be the optimum value of p to maximize the throughput of the MAC-21Z scheme. However, our performance evaluation suggests that the throughput associated with this value of p_2^\dagger is close to the optimum throughput of the MAC-21Z scheme, as discussed in Section IV.

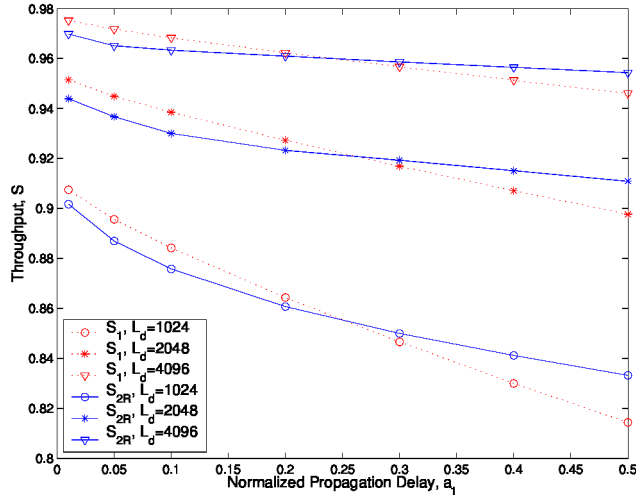

Fig. 5. Throughput comparison of MAC-1 and MAC-2R (p -persistent CSMA-based)

IV. NUMERICAL AND SIMULATION RESULTS

In this section, we present the numerical and simulation results of the comparison among the schemes. For the evaluation, we assumed that the channel data rate is 1 Mbps and that the control packet length is 48 bits.⁴ Our simulation, written in C language, implements a network with 50 nodes, with all the nodes being in the range of each other.

In Fig. 3, we compare the throughput performance of pure ALOHA-based MAC-1 and MAC-2R schemes for different data packet sizes and when $G = 0.5$. The straight lines represent the throughput of the MAC-1 scheme. The throughput of the MAC-2R scheme increases as r increases until the throughput reaches the maximum achievable value and then degrades. When r is small, it takes much longer time until a successful RTS/CTS dialogue occurs on the control sub-channel. However, when r is large, the fraction of the entire available channel used to transmit data is small, limiting the throughput of the MAC-2R scheme.

Comparing the throughput performance of the MAC-1 and the MAC-2R schemes, we observe that the MAC-1 scheme always out-performs the MAC-2R scheme, due to the nonzero waiting time on the data sub-channel in the MAC-2R scheme. As expected, the throughput of both schemes increases as the data packet length L_d (or k) becomes larger, approaching 1 as L_d (or k) increases. In Fig. 3, we also draw the simulation results of the MAC-2R scheme, demonstrating that our simulation results closely match those obtained by our analysis.

We have evaluated the throughput of the MAC-2R scheme for different G values and studied how far $G = 0.5$ is from the optimal G . The results are depicted in Fig. 4, where the relative throughput of the MAC-2R and the MAC-1 schemes, $\psi = S_{2R}/S_1$, is shown as a function of the ratio of the control sub-channel to the entire channel, r , for different data packet length, L_d . In our numerical calculations, the optimum G that maximizes the throughput of the MAC-2R scheme is calculated for each value of r . The traffic load of the MAC-1 scheme is always assumed to be 0.5. When $L_d = 1024$, the optimum throughput of the MAC-2R scheme is achieved at $r = 0.3$ with a traffic load $G = 0.478$, which is not far away from $G = 0.5$. Similar conclusions can be drawn for other values of L_d . Consequently, we concluded that using $G = 0.5$ introduces only marginal error in the optimal throughput calculation of the MAC-2R scheme. From Fig. 4, it can be observed that the maximum achievable throughput of the MAC-2R scheme is closer to the throughput of the corresponding MAC-1 scheme as L_d increases. Thus, the penalty for splitting the single channel is lower when the data packet length is larger. As L_d increases, the optimum r that achieves the maximum throughput for the MAC-2R scheme becomes smaller.

⁴ Although the evaluation was done for a particular set of parameter values, however, our results suggest that the conclusions remain unchanged for different parameters' values.

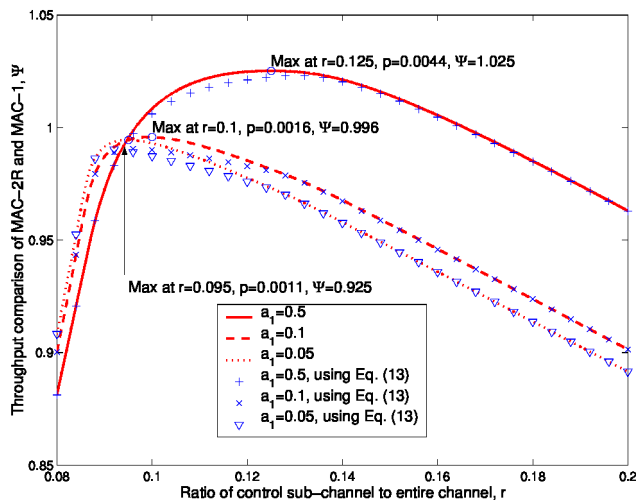

Fig. 6. Throughput comparisons between MAC-1 and MAC-2R with optimum traffic load, G (p -persistent CSMA-based)

Figure 5 compares the optimum throughput of p -persistent CSMA-based MAC-2R schemes with the throughput of the corresponding MAC-1 scheme as a function of the propagation delay, for different values of data packet length. As the data packet length, L_d , increases, the throughput of both schemes improve, which is the result of lower RTS/CTS overhead. As can be observed from this figure, the performance of both schemes degrade as the propagation delay increase. When propagation delay is zero (i.e., $a_1 = 0$), these two schemes achieve the same optimal throughput. When $a_1 \geq 0.25$, the throughput of the MAC-2R scheme is higher than the throughput of the MAC-1 scheme. From this figure, we conclude that, in the networks that we have studied, the p -persistent CSMA-based MAC-2R scheme out-performs the corresponding MAC-1 schemes when normalized propagation delay a_1 is larger than 25% of a control packet transmission time. Therefore, in order to achieve better throughput by splitting the single shared channel into two sub-channels in p -persistent CSMA-based MAC schemes, the propagation delay⁵ should be at least as large as 25% of the control packet transmission time on the single channel. This is in contrast with the case of the ALOHA access scheme, where the MAC-2R scheme always yields lower throughput compared to the MAC-1 scheme.

We have also studied the relative throughput of the MAC-2R scheme compared to that of the MAC-1 scheme with different values of p , and the results are presented in Fig. 6. In this figure, we show $\psi = S_{2R}/S_1$ as a function of the ratio r , for different values of a_1 . The lines represent the relative throughput of the MAC-2R scheme, when p is optimized for each value of r , while the symbols-curve provides the results calculated based on p_2^\dagger from (10). We also show in the figure the maximum values of ψ and their corresponding values of r and p . The p_2^\dagger values corresponding to the r values shown in the figure are: 0.0062, 0.0027, and 0.0019 for $a_1 = 0.5, 0.1$, and 0.05, respectively. Although the numbers shown in Fig. 6 indicate that the optimum values of p are somewhat smaller than the values of p_2^\dagger calculated from (10), nevertheless, this figure also shows that the error in throughput, created by selecting p_2^\dagger as the optimum p , is still negligible.

V. CONCLUDING REMARKS

Some previous publications in the literature claimed that the split-channel MAC scheme may achieve the same or even better throughput, as compared with the corresponding single-channel MAC scheme. However, these previous results were derived by considering only the expected value of the contention resolution periods, without taking into the account the random distribution of these periods. When the randomness of the contention resolution periods is considered, the split-channel schemes are inferior to the single-channel scheme in most of the scenarios that we have studied in this work. These scenarios include networks with negligible

⁵ In fact, such delay may represent transceiver turnaround time and other bandwidth-independent delays.

propagation delay and relatively large number of nodes, when pure ALOHA contention resolution technique is used, and networks with small propagation delays when p-persistent CSMA technique is used. According to our analysis, this result holds even if the split-channel schemes are optimized with respect to the ratio of the bandwidth of the control sub-channel to the bandwidth of the entire channel.

Even though our results are derived for MAC protocols that are based on the RTS/CTS dialogue, these results can be applied to other split-channel MAC schemes as well. In particular, these results can be useful for system engineers in evaluating the advantage and the disadvantage of splitting a single shared channel. It is worth pointing out that our results apply to the class of MAC protocols that are based on the RTS/CTS exchange but without any additional techniques. For instance, the MAC scheme in [4] uses power control to enable concurrent transmissions in the neighborhood and the throughput improvement has not been considered in our analysis. Such techniques may result in a different conclusion with respect to the comparison of MAC-1 and MAC-2R.

References:

- [1] F. A. Tobagi and L. Kleinrock, "Packet switching in radio channels: Part III-polling and (dynamic) split-channel reservation multiple access," *IEEE Trans. on Communications*, vol. COM-24, no. 8, pp. 832–845, August 1976.
- [2] X. Yang and N. H. Vaidya, "Explicit and implicit pipelining for wireless medium access control," in *Proc. of Vehicular Technology Conference (VTC)*, October 6 - 9 2003, Orlando, Florida, USA.
- [3] S. Singh and C. S. Raghavendra, "PAMAS - power aware multi- access protocol with signaling for ad hoc networks," *ACM Computer Communications Review*, vol. 28, no. 3, July 1998.
- [4] A. Muqattash and M. Krunz, "Power controlled dual channel (PCDC) medium access protocol for wireless ad hoc networks," in *Proceedings of the 21st International Annual Joint Conference of the IEEE Computer and Communications Societies (INFOCOM 2003)*, April 2003.
- [5] IEEE 802.11, "Wireless LAN MAC and physical layer specifications," June 1999.
- [6] J. Deng, Y. S. Han, and Z. J. Haas, "Analyzing split channel medium access control schemes with ALOHA reservation," in *Ad-Hoc, Mobile, and Wireless Networks - ADHOC-NOW '03*, S. Pierre, M. Barbeau, and E. Kranakis, Eds. 2003, vol. 2865 of *Lecture Notes in Computer Science (LNCS)*, pp. 128–139, Springer-Verlag.
- [7] H. Takagi and L. Kleinrock, "Output processes in contention packet broadcasting systems," *IEEE Trans. on Communications*, vol. COM-33, no. 11, pp. 1191–1199, November 1985.
- [8] J. Abate and W. Whitt, "Numerical inversion of Laplace transforms of probability distributions," *ORSA J. Computing*, vol. 7, no. 1, pp. 36–43, Winter 1995.